

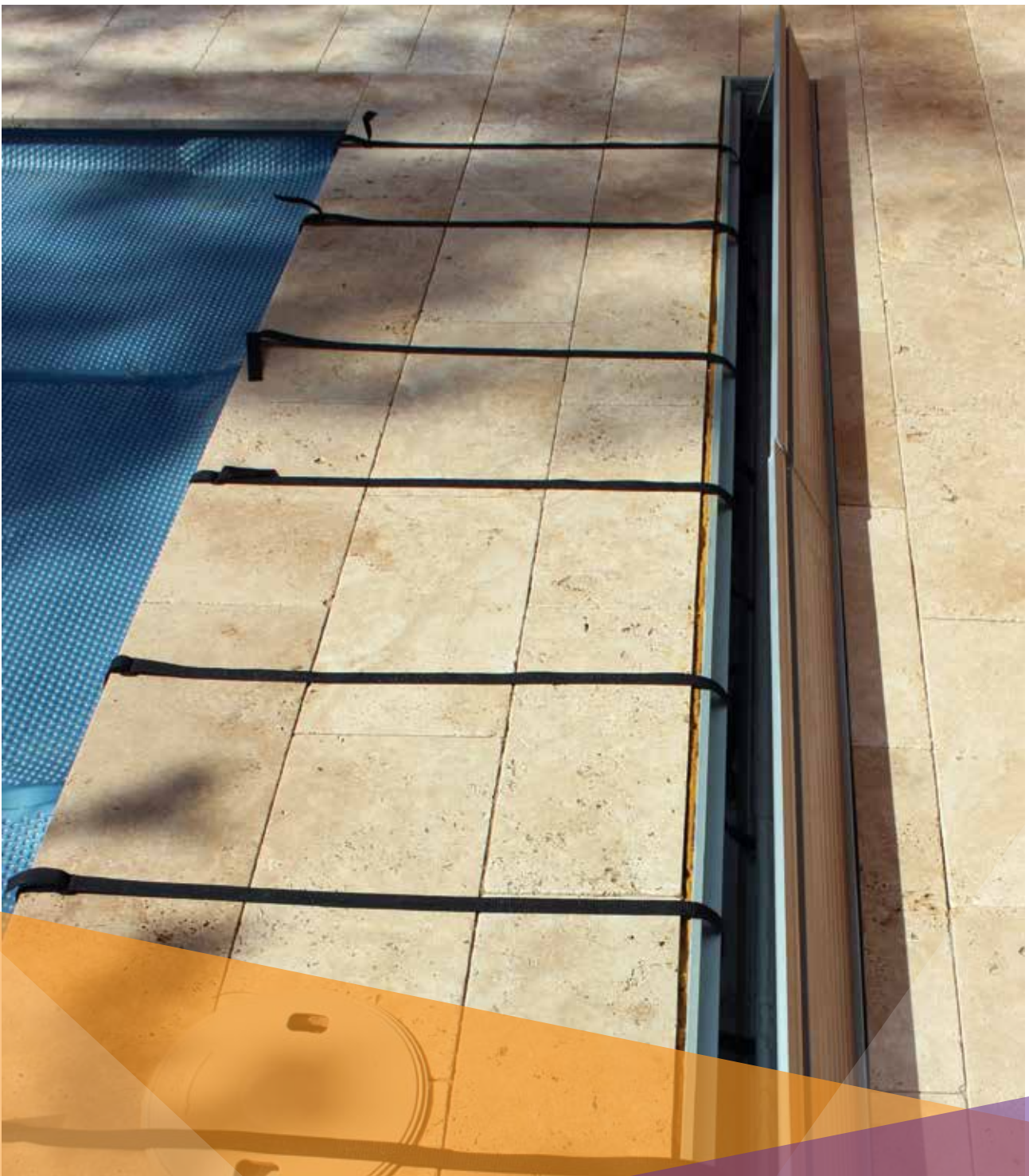

# UNDERGROUND BLANKET BOX INSTALLATION GUIDE



## STEP 1

Prior to digging it is crucial that the headers have been installed. Headers are the coping or cap on the edge of the Swimming Pool.

Headers determine the positioning or placement of the Underground Blanket Box (UBB).



## STEP 2

Dig and check that all pipes and cables are not in the way of where the UBB will be installed.

This should be specified to pool builder prior to construction of your pool.



## STEP 3

Measure width of pool and allow 150 to 200mm **either side** so that the blanket can retract on the UBB without getting tangled.

Also as a guide measure 300 to 400mm (or the width of the pavers that would go in between) from the header to the lid.

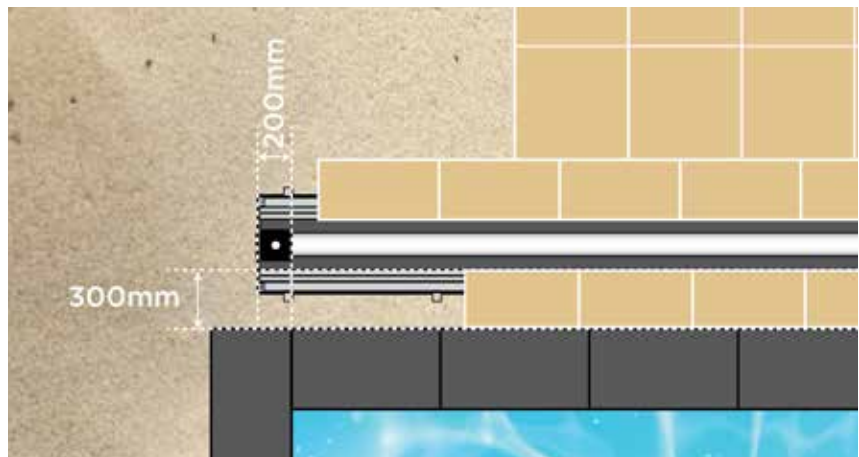

## STEP 4

Dig a hole that's approximately

- 600mm deep
- 600mm wide
- Add 200mm to the length of the UBB

This is so that the UBB has enough room to moved and adjusted if needed.

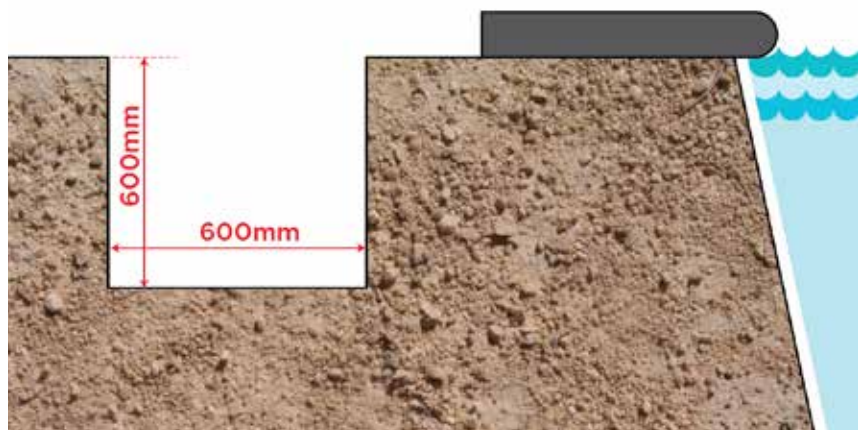



## STEP 5

Place UBB into the hole ensuring the lid opens in the correct direction.

Also check that lid height is level with finished floor level and box is parallel to the pool headers.

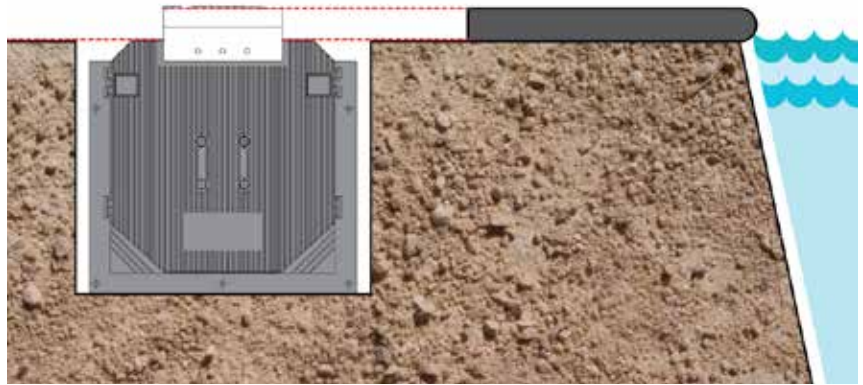

## STEP 6

Back fill both ends of box approximately 100mm deep. Using a hose, water both ends to ensure compaction.

Double check all measurements and levels to ensure box has not moved.

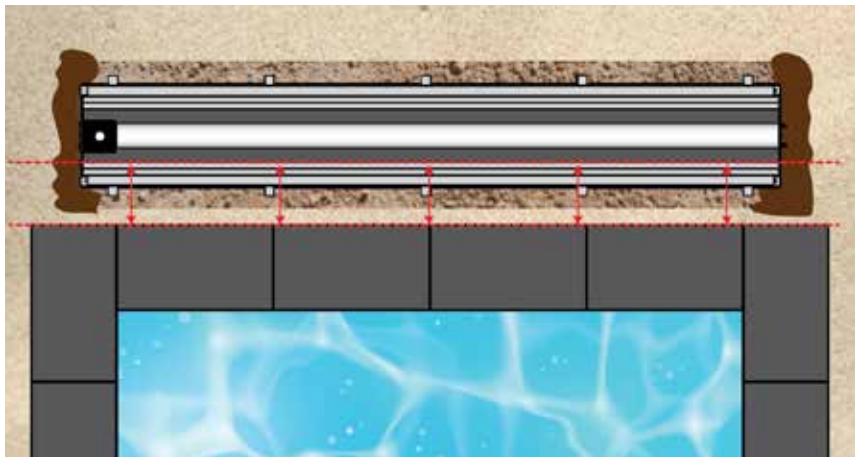

## STEP 7

Use rapid set concrete and pour down the braces to help lock the UBB into position. Then proceed to back fill to complete installation.



## STEP 8

Ensure all sand and debris is removed from lid and cover it to protect it.

### DO NOT

- walk on lid
- machine compact around roller box
- acid wash near lid

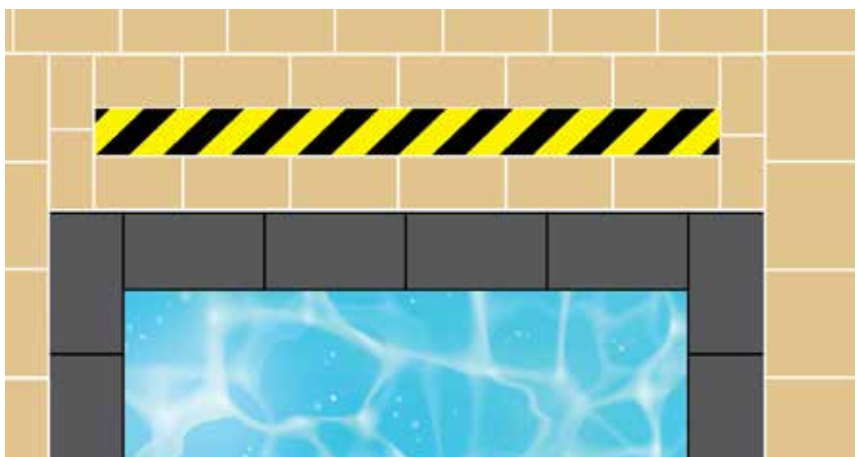

## STEP 9

If the blanket is cut to size, open the lid, extend straps and hook it up to the eyelets.

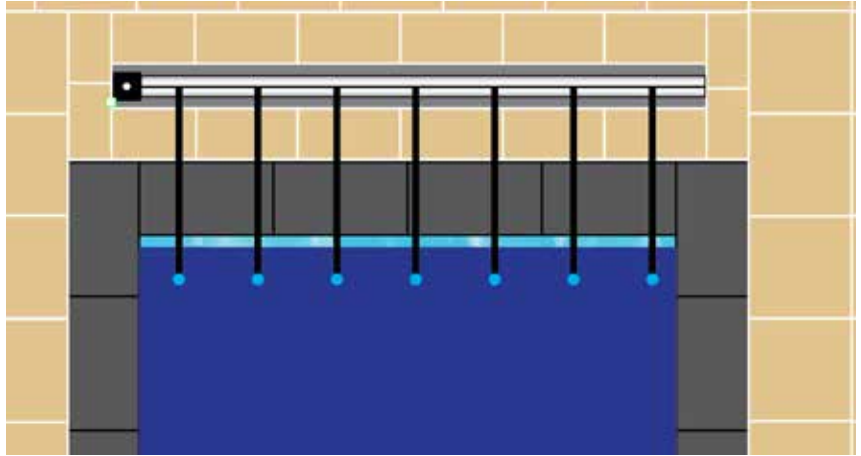

This picture has a different clip arrangement to step 9



# DIMENSIONS

## TOP VIEW

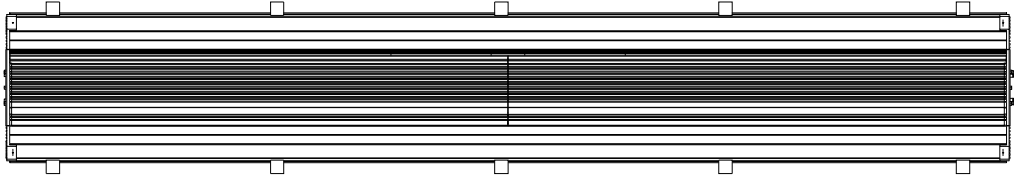

## SIDE VIEW

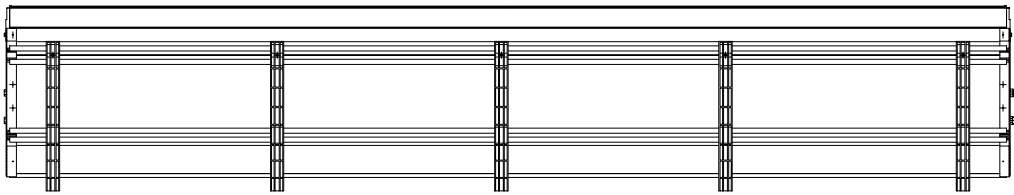

## 3D VIEW

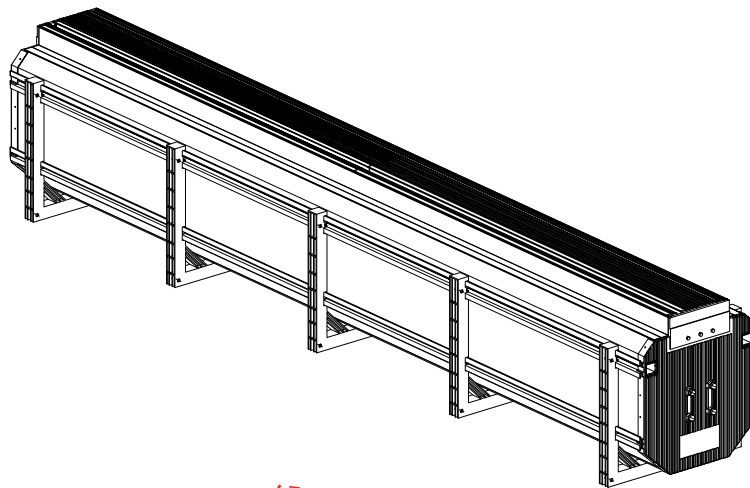

## END VIEW

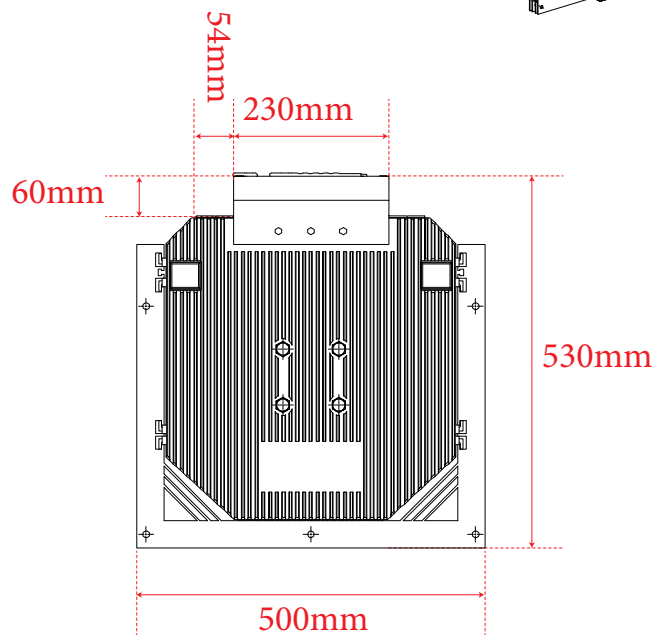



## CONTACT US

### MELBOURNE

Address: 27 Westwood Drive, Deer Park, Vic 3023  
Phone: (03) 9390 0700  
Email: [sales@sunlineaustralia.com.au](mailto:sales@sunlineaustralia.com.au)  
Web: [www.sunlineaustralia.com.au](http://www.sunlineaustralia.com.au)

### ADELAIDE

Address: 152 Frederick St, Welland SA 5007  
Phone: 0419 857 987  
Email: [info@sunlinesa.com.au](mailto:info@sunlinesa.com.au)  
Web: [www.sunlineaustralia.com.au](http://www.sunlineaustralia.com.au)

### PERTH

Address: Unit 2, 10 Competition Way, Wangara WA 6065  
Phone: (08) 9303 4347  
Email: [info@sunlinewa.com.au](mailto:info@sunlinewa.com.au)  
Web: [www.sunlineaustralia.com.au](http://www.sunlineaustralia.com.au)

 [sunline\\_australia](#)  [sunline australia](#)  [sunlineaustralia](#)